

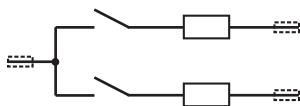

- (D)** Betriebsanleitung
Maschinensicherheitssensoren Serie 120..2
- (GB)** Operating instructions
Machine safety sensors series 120..2
- (F)** Notice d'utilisation
Capteurs de sécurité pour machines série 120..2
- (I)** Istruzioni d'impiego
Sensori di sicurezza per macchine serie 120..2

1

1 BN



BK 2

BU 3

2

1 WH

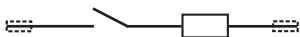

BN 2

3 GN(+)



YE 4

3

1 WH



2 BN

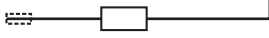

3 GN(+)



4 YE



4

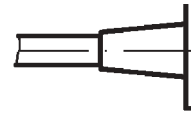
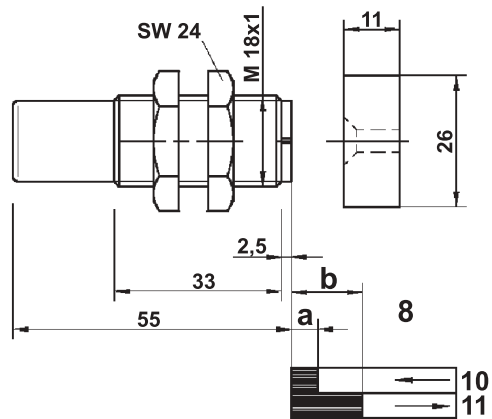

5

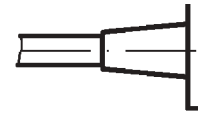

6

4

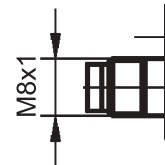
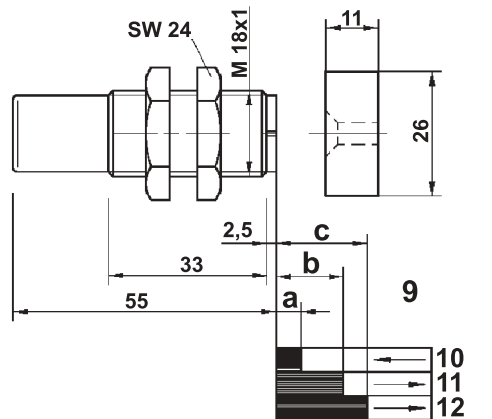

7

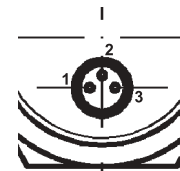

1 Technical Specification

1.1 General

The foldout shows the various contact configurations and the mechanical data for the various model options.

Contact configurations

1. Base model 120 262
2. Base model 120 V62
3. Base model 120 272

Mechanical Data

4. Mechanical details of the various base models

Connection to the various models

5. Cable LIYY 3 x 0.25 mm²
6. Cable LIYY 4 x 0.25 mm²
7. Connector M8 x 1 (3-pole)

Switching formats

8. Switching characteristics for base model 120 272
9. Switching characteristics for base models 120 262, 120 V62

Switching functions

10. On
11. Off
12. Off (both contacts changed state allowing re-start)

The different features of the various base models are described in these instructions. Individual data sheets are available, on request, from elobau.

1.2 Electrical specification

Switched voltage (V DC)	24
Switched current (mA)	100 (max.)
Series resistor (Ohm)	22
Switching capacity (W)	3
Shock resistance (Hz/g)	10 ... 2000/35
Protection class	IP 67 (IEC 529)

1.3 Mechanical specification

Housing material	Fibreglass reinforced PBT (Pocan) or VA
Temperature range (°C)	-25 ... 75

1.4 Actuating magnets

Possible actuating magnets	304 200 00. 304 200 00 S. (S = stronger) 304 200 00 VS. (S = stronger)
----------------------------	--

Air gap (mm) (switching distance) for safe switching function (base models only):

	MIN.		ON		OFF		OFF *	
	N	S	N	S	N	S	N	S
120 272	0.5	3	4	7	13	17	22	23
120 262 120 V62	0.5	3	4	7	18	20		

N Normal

S Stronger

* Both contacts change state

MIN. Minimum air gap

Note Only use strong type magnets when an operating gap of more than 4 mm is required.

1.5 Identification

The machine safety sensors are marked with the following information.

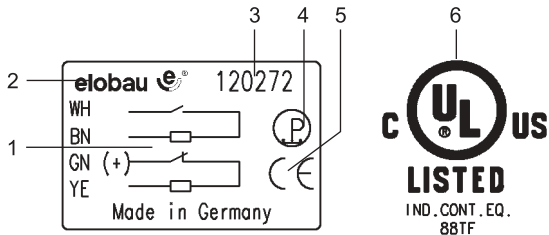

1. Contact format
2. elobau logo
3. Type no.
4. Personnel protection symbol
5. CE mark
6. UL mark (where applicable see list)

2 Intended use

2.1 Area of application

- The machine safety sensors should only be used as specified by the manufacturer.
Should they be used incorrectly, all guarantees and liabilities of the manufacturer will be void.
- Ensure that the safety requirements of individual machines are complied with.
- Ensure that International, European and National regulations are adhered to.

2.2 Standards and Guidelines

The machine safety sensors are approved according to the Low Voltage Directive 73/23/EEC and Machine Directive 89/392/EEC.

The following models have USL/CNL approval:

Environmental Type 1, Type of ESPE Type 2

- ➔ 120 262
- ➔ 120 V62
- ➔ 120 272

2.3 Safety/hazards

- For personnel protection when used in conjunction with an approved safety assessment.
- Only operate the machine safety sensors if they are totally undamaged.
- When mounting, ensure the alignment marks on both the sensor and actuating magnet are facing each other.

3 Function

3.1 Function

These non contacting machine safety sensors utilise reed contacts. A control unit monitors the sensor for all open and short circuits. A coded magnet is used to operate the sensor without making physical contact.

- Observe regulations for personnel safety.

When the standard actuating magnet is moved towards and away from the sensor (see Actuating magnets), the following takes place:

<i>Distance</i>	<i>Control unit</i>
$\leq a$ and ≥ 0.5 mm	On
$\geq b$	Off (cannot be switched on from this position)
$\geq c$	Off (can be switched on again)

3.2 Models

The machine safety sensors differ mainly in their contact formats (see contact configurations on the inside of the foldout):

<i>Model</i>	<i>Contact configuration</i>
120 262	Two Normally Open contacts, 3 wire
120 V62	Two Normally Open contacts, 4 wire
120 272	Normally Open/Normally Closed contacts, 4 wire

The machine safety sensors are divided into catalogue models and customer specific models. The catalogue versions are based upon the above base models.

Examples

Base model: 120 272

Catalogue model: 120 272 AY

Customer-specific model: 120 272 AY01

For other differences, see Technical Specification.

These machine safety sensors are suitable for use with the following elobau control units:

Two Normally Open contacts, 3 wire and Two Normally Open contacts, 4 wire

- 462 141 E1
- 462 141 H1
- 462 M41 H3
- 462 M41 H31
- 462 M41 H34
- 462 M51 H1
- 462 M51 H11
- 462 M51 H21

Normally Open/Normally Closed contacts, 4 wire

- 462 121 G1
- 462 121 E
- 462 121 H
- 463 12.

For appropriate combinations of machine safety sensor systems and control units see Models.

4 Mounting

4.1 Mounting

- ⊕ Ensure that the alignment marks on both the sensor and the actuation magnet are facing each other. Any mounting arrangement is acceptable.
- ⊕ Do not install sensor and magnet on ferrous material. Where necessary, use a 20 mm non ferrous spacer.
- ⊕ Use non ferrous screws for mounting the actuation magnet. The plastic socket head screw insert 351040 can be used with countersunk screws to DIN 7991/M5 to prevent easy removal.
- ⊕ Ensure that the sensor and actuating magnet are not installed in the presence of strong magnetic fields.
- ⊕ Keep away from ferrous swarf.

- Ensure that sensors and actuating solenoid are not used as mechanical stops.
- Ensure that the tightening torque of the plastic nuts does not exceed 3 Nm.
- Ensure that the mounting distance between two sensors is at least 50 mm.
- Take note of the mounting tolerances of ± 2.5 mm or 3 mm as shown:

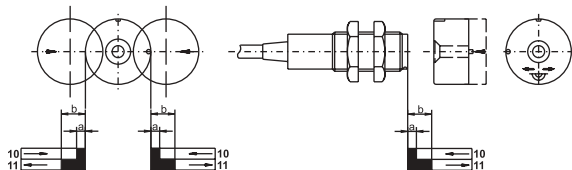

The unit is triggered:

- When magnet approaches directly
- When magnet approaches laterally

Note Observe the alignment marks on both the sensor and the actuation magnet.

4.2 Connection

The sensors are connected either by fixed cable or by cable with plug & socket (see Technical Specification).

- Observe the specified limits.
- Protect the cables from mechanical damage.

4.3 Commissioning

- Ensure that the guards equipped with the machine safety sensors are only operated by trained personnel.
- Ensure that the machine safety sensors are being used in the correct manner (see Intended use).

5 Maintenance

5.1 Measures

- Do not modify the machine safety sensors.
- Only replace failed units with original spare parts, approved for use.
- Determine suitable inspection intervals depending upon the application and the working environment.

5.2 Disposal

- Dispose of used parts and unwanted packaging in accordance with the regulations of the country in which the device is installed.

Datum: 15.10.2003

elobau 

elobau
Elektrobauelemente GmbH & Co. KG

Postfach 1265
88306 Isny/Allgäu
Germany

Werk:
Zeppelinstr. 44
88299 Leutkirch
Germany
Tel.: +49 75 61/970 - 0
Fax: +49 75 61/970 - 100
E-Mail: info@elobau.de
Web: www.elobau.de

 0123