

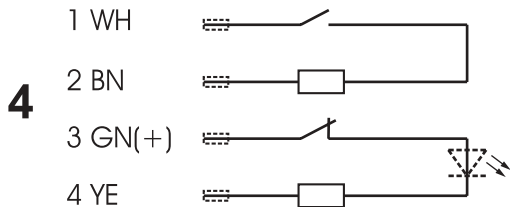

- (D) Betriebsanleitung**
Maschinensicherheitssensoren Serie 161
- (GB) Operating instructions**
Machine safety sensors series 161
- (F) Instructions d'opération**
Capteurs de sécurité pour machines série 161
- (I) Istruzioni d'impiego**
Sensori di sicurezza per macchine serie 161

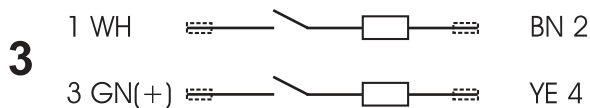

5

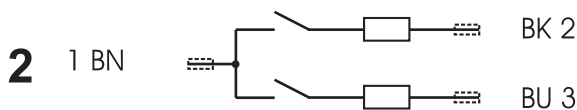
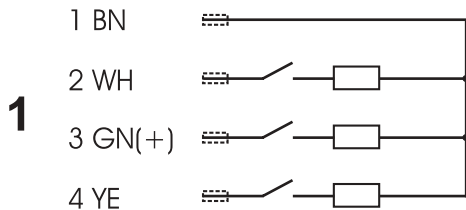
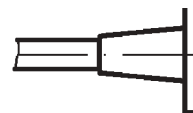
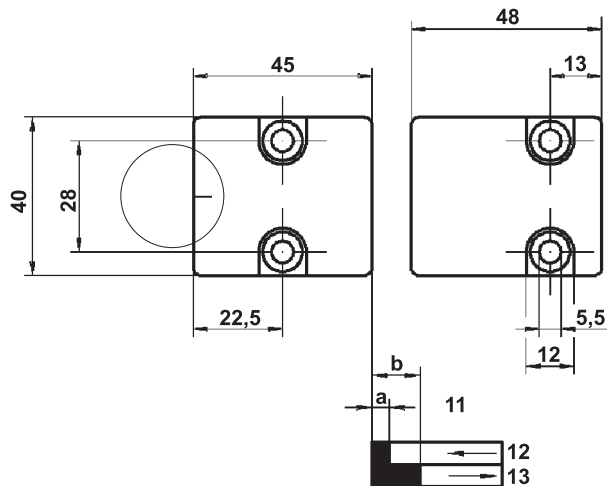

6

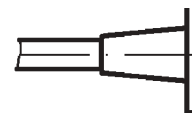

7



8



5

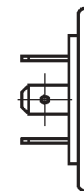
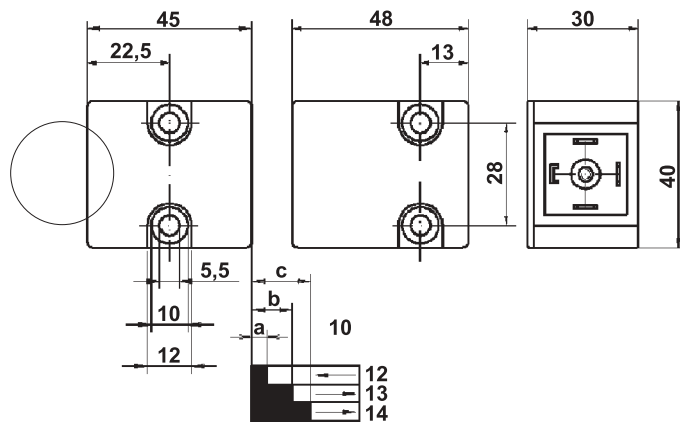

9

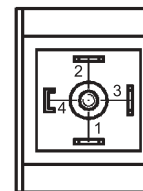

1 Technical Specification

1.1 General

The foldout shows the various contact configurations and the mechanical data for the various model options.

Contact configurations

1. Base model 161 261
2. Base model 161 262
3. Base model 161 V62
4. Base model 161 271 (depending on model with LED)

Mechanical data

5. Mechanical details of the various base models

Connection to the various models

6. Cable LIYY 3 x 0.25 mm²
7. Cable LIYY 4 x 0.25 mm²
8. Torson plug (4-pole)
9. Hirschmann Plug to DIN 43650

Switching formats

10. Switching characteristics for base model 161 271
11. Switching characteristics for base models 161 261, 161 262, 161 V62

Switching functions

12. On
13. Off (one contact changed state)
14. Off (both contacts changed state, allowing restart)

The different features of the various base models are described in these instructions. Individual data sheets are available, on request, from elobau.

1.2 Electrical specification

| | |
|-------------------------|-----------------|
| Switched voltage (V DC) | 24 |
| Switched current (mA) | 100 (max.) |
| Series resistor (Ohms) | 22 |
| Switching capacity (W) | 3 |
| Shock resistance (Hz/g) | 10 ... 2000/35 |
| Protection class | IP 67 (IEC 529) |

1.3 Mechanical specification

| | |
|------------------------|-----------------------------------|
| Housing material | Fibreglass reinforced PBT (Pocan) |
| Temperature range (°C) | -25 ... 75 |

1.4 Actuation magnets

| | |
|----------------------------|---|
| Possible actuation magnets | 304 221 12. 304 221 12 S 304 221 02 |
|----------------------------|---|

Air gap (mm) (switching distance) for safe switching function (base models only):

| | MIN. | | ON | | OFF | | OFF * | |
|--------------------|------|---|----|---|-----|----|-------|----|
| | N | S | N | S | N | S | N | S |
| 161 271 | 0,5 | 3 | 4 | 7 | 11 | 17 | 16 | 23 |
| 161 261 | 0,5 | 3 | 4 | 7 | 14 | 20 | | |
| 161 262 161 V62 | 0,5 | 3 | 4 | 7 | 16 | 20 | | |

N Normal

S Strong

* Both contacts changed state

MIN. Minimum air gap

Note Only use strong type magnets when an operating gap of more than 4 mm is required.

1.5 Marking

All machine safety sensors are marked with the following information.

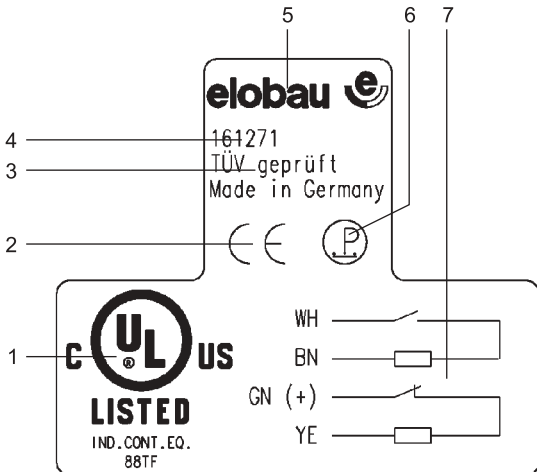

1. UL mark (where applicable, see list)
2. CE mark
3. TÜV Certification mark
4. Type no.
5. elobau logo
6. Personnel protection symbol
7. Contact format

2 Intended use

2.1 Application

- The machine safety sensors should only be used as specified by the manufacturer.
Should they be used incorrectly, all guarantees and liabilities of the manufacturer will be void.
- Ensure that the safety requirements of individual machines are complied with.
- Ensure that International, European and National regulations are adhered to.

2.2 Standards and Directives

The machine safety sensors are approved according to the Low Voltage Directive 73/23/EEC and Machine Directive 89/392/EEC.

The following models have USL/CNL approval:

Environmental Type 1, Type of ESPE Type 2

- ➔ 161 262
- ➔ 161 262 AFA
- ➔ 161 V62
- ➔ 161 271
- ➔ 161 271 AA
- ➔ 161 271 AOD
- ➔ 161 271 AOE

2.3 Safety/hazards

- For personnel protection when used in conjunction with an approved safety assessment.
- Only operate the machine safety sensors if they are totally undamaged.
- When mounting, ensure the alignment marks on both the sensor and actuating magnet are facing each other.

3 Function

3.1 Function

These non contacting machine safety sensors utilise reed contacts. A control unit monitors the sensor for all open and short circuits. A coded magnet is used to operate the sensor without making physical contact.

- Observe regulations for personnel safety.

When the standard actuating magnet is moved towards and away from the sensor (see Actuation magnets), the following takes place:

| <i>Distance</i> | <i>Control unit</i> |
|----------------------------|--|
| $\leq a$ and ≥ 0.5 mm | On |
| $\geq b$ | Off (cannot be switched on from this position) |
| $\geq c$ | Off (can be switched on again) |

3.2 Models

The machine safety sensors differ mainly in their contact formats (see contact configurations on the inside of the foldout).

| <i>Model</i> | <i>Contact configuration</i> |
|--------------|--|
| 161 261 | Three Normally Open contacts, 4 wire |
| 161 262 | Two Normally Open contacts, 3 wire |
| 161 V62 | Two Normally Open contacts, 4 wire |
| 161 271 | Normally Open/Normally Closed contacts, 4 wire |

The machine safety sensors are divided into catalogue and customer specific models. The catalogue versions are based upon the above base models.

Examples

Base model: 161 271

Catalogue model: 161 271 AB

Customer-specific model: 161 271 AB01

For other differences, see Technical Specifications.

These machine safety sensors are suitable for use with the following elobau control units:

- 161 261
 - 463 13.
 - 462 151 G
- 161 262/161 V62
 - 462 141 E1
 - 462 141 H1
 - 424 151 H1
 - 462 M41 H3
 - 462 M51 H1
- 161 271
 - 462 12 G1
 - 462 121 E
 - 462 121 H
 - 463 12.

4 Mounting

4.1 Mounting

- ⊕ Ensure that the alignment marks on both the sensor and the actuation magnet are facing each other.
Any mounting arrangement is acceptable.
- ⊕ Do not install sensor and magnet on ferrous material. Where necessary, use a 20 mm non ferrous spacer.
- ⊕ Use washer 350 002 for sensor 161 271 and washer 350 003 for magnet 304 221 12, if necessary.
- ⊕ Use non ferrous screws for mounting the actuation magnet. The plastic socket head screw insert 351041 can be used with cap screws to DIN 912/M5 to prevent easy removal.
- ⊕ Ensure that the sensor and actuating magnet are not installed in the presence of strong magnetic fields.
- ⊕ Keep away from ferrous swarf.
- ⊕ Ensure that the sensors and actuation magnets are not used as mechanical stops.
- ⊕ Ensure that the mounting distance between two sensors is at least 50 mm.

- ☞ Take note of the mounting tolerances of ± 2 mm or ± 3 mm as shown below:

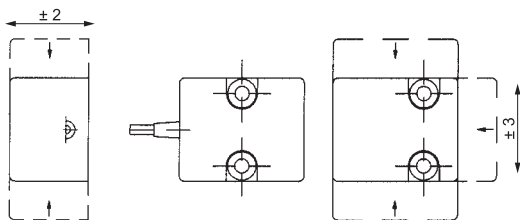

The unit is triggered

- ➔ When magnet approaches directly
- ➔ When magnet approaches laterally

Note Observe the alignment marks on both the sensor and the actuation magnet.

4.2 Connection

The sensors are connected either by fixed cable or by cable with plug & socket (see Technical Specification).

- ☞ Observe the specified limits.
- ☞ Protect the cables from mechanical damage.

Note Where several sensors with LED are connected together, the brightness of the LEDs decreases with the number of open guards.

4.3 Commissioning

- Ensure that the guards equipped with the machine safety sensors are only operated by trained personnel.
- Ensure that the machine safety sensors are being used in the correct manner (see Intended use).

5 Maintenance

5.1 Measures

- Do not modify the machine safety sensors.
- Only replace failed units with original spare parts, approved for use.
- Determine suitable inspection intervals depending upon the application and the working environment.

5.2 Disposal

- Dispose of used parts and unwanted packaging in accordance with the regulations of the country in which the device is installed.

Datum: 19.08.2003

elobau 

elobau
Elektrobauelemente GmbH & Co. KG

Postfach 1265
88306 Isny/Allgäu
Germany

Werk:
Zeppelinstr. 44
88299 Leutkirch
Germany
Tel.: +49 75 61/970 - 0
Fax: +49 75 61/970 - 100
E-Mail: info@elobau.de
Web: www.elobau.de

 0123