

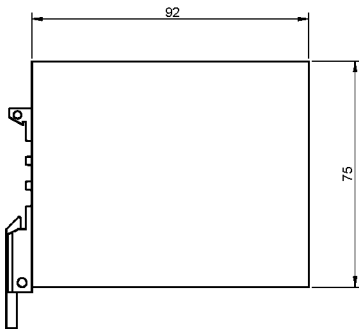

**462 M51 H11**  
**462 M51 H21 A**

- (D)** Betriebsanleitung  
MSS-Zentraleinheit
- (GB)** Operating instructions  
MSS central processing unit
- (F)** Notice d'utilisation  
Unité centrale MSS
- (I)** Istruzioni d'impiego  
Unità centrale MSS

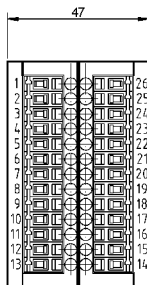

### 462 M51 H11

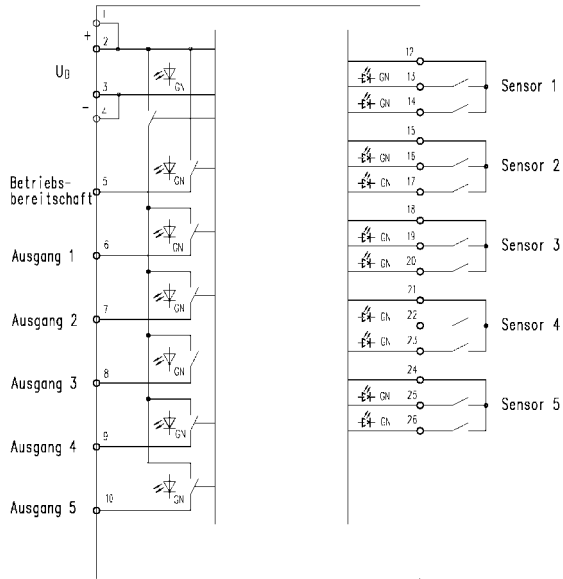

### 462 M51 H21 A

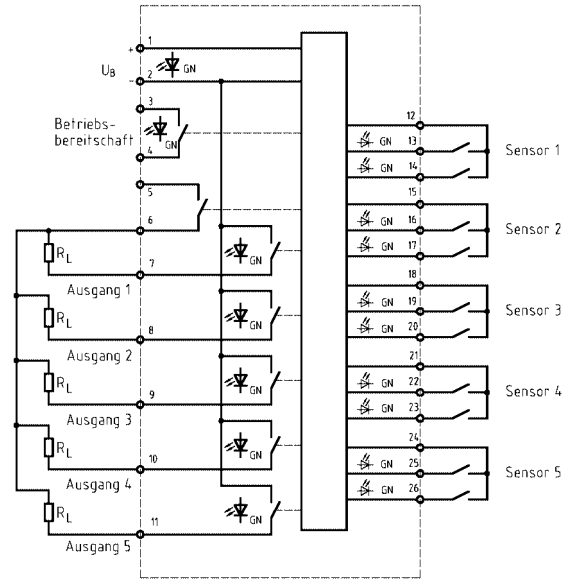

# 1 Technical Specification

## 1.1 Terminal assignment

### General

A maximum of five sensors can be directly connected to the Central Control unit.

To connect additional sensors, elobau interface 363 V98 or 364 097 are recommended.

### Version 462 M51 H11

<i>Terminal</i>	<i>Assignment</i>
1, 2	Supply voltage (+)
3, 4	Supply voltage (-)
5	Output Ready (no faults detected)
6	Safety output 1
7	Safety output 2
8	Safety output 3
9	Safety output 4
10	Safety output 5
11	n.c.
12, 13, 14	Sensor 1 (link out if not required)
15, 16, 17	Sensor 2 (link out if not required)
18, 19, 20	Sensor 3 (link out if not required)
21, 22, 23	Sensor 4 (link out if not required)
24, 25, 26	Sensor 5 (link out if not required)

**Option 462 M51 H21 A**

<b><i>Terminal</i></b>	<b><i>Assignment</i></b>
1	Supply voltage (+)
2	Supply voltage (-)
3, 4	Output Ready (no faults detected)
5, 6	mutual switching contact
7	Safety output 1
8	Safety output 2
9	Safety output 3
10	Safety output 4
11	Safety output 5
12, 13, 14	Sensor 1 (link out if not required)
15, 16, 17	Sensor 2 (link out if not required)
18, 19, 20	Sensor 3 (link out if not required)
21, 22, 23	Sensor 4 (link out if not required)
24, 25, 26	Sensor 5 (link out if not required)

## 1.2 Model Numbering system

The following example and table demonstrates the numbering system used for elobau machine safety central control units:

- Example:
- 462 M51 H21 A
- 4ab cde fgh i

<b>Notation</b>	<b>Characteristic</b>		<b>Meaning</b>
4ab	Housing type and width	462	Housing width 47 mm
		463	Housing width 25 mm
c	Model	M	Micro-Processor based
d	Number of inputs	5	5 inputs
e	Supply voltage	1	24 V AC/DC $\pm 10\%$ FELF (one side must be earthed)
f	Others	H	Protection class 4 to EN 954-1
g	Safety output	1	PNP
		2	NPN
h	Switching voltage	1	24 V AC/DC
i	Customer-specific	A	Special model

### 1.3 Electrical and mechanical specifications

In the circuit diagram shown on the foldout page, the Control unit is shown without voltage applied.

#### General

Supply voltage	24 V DC; $\pm 10\%$ FELF (one side must be earthed)
Current input	200 mA
max. switching voltage Control output	30 V AC/DC
max. switching current Control output	1,0 A AC/DC
max. switching power Control output	30 VA
max. switching voltage Safety outputs	30 V DC
max. switching current Safety outputs	0,5 A/channel (short-circuit proof)
max. switching power Safety outputs	15 W
Operating temperature	0° ... +55° C
Transport and storage temperature	-25° ... +85° C
Vibration and shock resistance	Oscillation: 10 ... 55 Hz, 1 mm Shock: 30 g / 11 ms Continuous shock: 10 g / 16 ms
Protection class, housing	IP 40
Protection class, terminals	IP 20

**Supply voltage fuse**

<i>Type</i>	<i>supply fuse</i>
462 M51 H11	3,0 A
462 M51 H21 A	1,0 A

**Safety outputs fuse**

<i>Type</i>	<i>supply fuse</i>
462 M51 H21 A	3,0 A

**Safety output type**

<i>Type</i>	<i>output</i>
462 M51 H11	PNP
462 M51 H21 A	NPN

**Delay time**

The delay time is the maximum time during which the 2 sensor contacts can be in different switching states before the Control unit locks out.

<i>Type</i>	<i>Delay time</i>
462 M51 H11 462 M51 H21 A	3 s

**LED display**
**Variant 462 M51 H11**

<b><i>LED at terminal</i></b>	<b><i>Color</i></b>	<b><i>Meaning</i></b>
2	green	Supply voltage ON
5	green	Ready (no fault detected)
6	green	Safety output 1 switched
7	green	Safety output 2 switched
8	green	Safety output 3 switched
9	green	Safety output 4 switched
10	green	Safety output 5 switched
13	green	Sensor 1, first contact closed
14	green	Sensor 1, second contact closed
16	green	Sensor 2, first contact closed
17	green	Sensor 2, second contact closed
19	green	Sensor 3, first contact closed
20	green	Sensor 3, second contact closed
22	green	Sensor 4, first contact closed
23	green	Sensor 4, second contact closed
25	green	Sensor 5, first contact closed
26	green	Sensor 5, second contact closed

## Variant 462 M51 H21 A

<b><i>LED at terminal</i></b>	<b><i>Color</i></b>	<b><i>Meaning</i></b>
2	green	Supply voltage ON
4	green	Ready (no faults detected)
7	green	Safety output 1 switched
8	green	Safety output 2 switched
9	green	Safety output 3 switched
10	green	Safety output 4 switched
11	green	Safety output 5 switched
13	green	Sensor 1, first contact closed
14	green	Sensor 1, second contact closed
16	green	Sensor 2, first contact close
17	green	Sensor 2, second contact closed
19	green	Sensor 3, first contact closed
20	green	Sensor 3, second contact closed
22	green	Sensor 4, first contact closed
23	green	Sensor 4, second contact closed
25	green	Sensor 5, first contact closed
26	green	Sensor 5, second contact closed

## 2 Intended use

The intended use of the MSS Central Control unit is to exclusively protect against safety hazards.

### 2.1 Standards and Guidelines

The MSS Central Control unit complies with the following European directives:

- ➔ 73/23/EEC (low-voltage directive)
- ➔ 89/336/EEC (electromagnetic-compatibility directive)
- ➔ 89/37/EC (Machinery directive)

The MSS Central Control unit was subjected to EU prototype testing at TÜV/IQSE in Munich, Germany.

The MSS Central Control unit complies with the following standards:

<b><i>Standard</i></b>	<b><i>Subject</i></b>
EN 954-1/ category 4	Safety of machines
EN 60 204	Electrical equipment for industrial machinery
DIN V 19250	Basic safety overview of protective equipment, category 5
DIN V 19251	Protective equipment: requirements and measures for safety function
Draft IEC 61508	Functional safety - safety relevant systems SIL3 (application during test intervals)
EN 50178	Electronic equipment for use in power installations

<b>Standard</b>	<b>Subject</b>
IEC 664-1	Insulation co-ordinates in low-voltage switch gear
DIN EN 60068	Basic environmental test procedures
EN 50081-2	EMC emission (interference) in industrial environments
EN 50082-2	EMC immunity in industrial environments
EN 55011	Interference suppression of electrical equipment and systems

## 2.2 Safety/hazards

- Ensure that the MSS Central Control unit is only installed and commissioned by qualified and authorised personnel.
- Ensure that correct fuses are used (see Technical Specification).
- Operate the MSS Central Control unit only if it is completely undamaged.
- Ensure that the MSS Central Control unit is only used for protection against safety hazards.
- Ensure that all relevant safety instructions and regulations for the machine concerned are always followed.
- Ensure that all applicable European directives and national statutory requirements/directives are followed.
- Ensure that the control output is only used for displaying the operating condition of the MSS Central Control unit.

### 3 Function

#### General

The MSS Central Control unit monitors safety sensors having 2 x Normally Open contacts. The switched condition of the safety outputs will depend upon whether the respective sensor is operated or not. Each sensor controls its respective safety output (e.g. sensor 1 controls safety output 1).

The MSS Central Control unit switches off individual safety outputs, when

- ➔ any one contact of the respective sensor is opened,
- ➔ a fault occurs in the MSS Central Control unit or one of the sensors becomes defective.

#### Variant 462 M51 H11

The MSS Central Control unit switches off all safety outputs and the Ready LED, when:

- ➔ the 2 contacts of any sensor are in different switching states for a period exceeding 3 seconds,
- ➔ a fault occurs in the MSS Central Control unit or one of the sensors becomes defective.

#### Variant 462 M51 H21 A

The MSS Central Control unit switches off the mutual switching contact and the Ready LED, when:

- ➔ the 2 contacts of any sensor are in different switching states for a period exceeding 3 second,
- ➔ the mutual switching contact is faulty,
- ➔ a fault occurs in the MSS Central Control unit or one of the sensors becomes defective.

## 4 Assembly



**Danger**

### **Danger of fatal electric shock**

- Ensure that the MSS Central Control unit is only installed and commissioned by trained and authorised personnel.

- Install the MSS Central control unit into the control cabinet by snapping it onto a DIN rail (DIN 50 022).

The MSS central processing unit is fixed now.

- Make all necessary connections to the MSS Central Control unit (see Technical Specification).
- Ensure that the correct fuses are used (see Technical Specification).

## 5 Commissioning



**Danger**

### **Danger of electrocution**

- Ensure that the MSS Central Control unit is only installed and commissioned by trained and authorised personnel.

- Apply the supply voltage.

The MSS central unit carries out an internal self test (duration: > 10 sec).

After successful completion of the test:

- ➔ The MSS Central Control unit safety outputs will close.
- ➔ The Ready LED will illuminate.
- ➔ The unit is now operational.

## 5.1 System reset

### **Both Normally Open contacts of a sensor open**

If a safety output switches off because both Normally Open contacts of the respective sensor open:

- Close both contacts on the respective sensor.

The MSS Central Control unit closes the respective safety output. The respective LEDs illuminate.

### **Contacts in different switched states**

Should the contacts of one sensor not be in the same switched state for a period exceeding 3 seconds, the safety outputs will switch off and the Ready LED will go off.

To restore the system, ensure that both the normally open contacts of the relevant sensor are open.

Ready LED will illuminate. The MSS Central Control will once again be operational.

All the MSS Central Control unit safety outputs will close and the respective LEDs will illuminate.

- Close both contacts on the respective sensor.

The MSS Central Control unit will close the respective safety output and the respective LEDs will illuminate.

## 5.2 Safety output remains switched off

- Check connections at input and output terminals:
  - Supply voltage

All sensors connected:

- Replace MSS Central Control unit.

## 6 Maintenance

### Automatic test of MSS Central Control unit

- ↻ In order to ensure operational reliability of the MSS Central Control unit the self test Function should be initiated every three months.
- ↻ Switch operating voltage off and on again.

The MSS Central Control unit will perform the self test (duration: >10 sec).

After successful completion of the self test:

- ➔ The safety outputs will close and the respective LEDs will illuminate.
- ➔ The Ready LED will illuminate.
- ➔ The MSS Central Control unit is now operational.

Datum: 24.06.2004

**elobau** 

**elobau**  
**Elektrobauelemente GmbH & Co. KG**

Postfach 1265  
88306 Isny/Allgäu  
Germany

Werk:  
Zeppelinstr. 44  
88299 Leutkirch  
Germany  
Tel.: +49 75 61/970 - 0  
Fax: +49 75 61/970 - 100  
E-Mail: [info@elobau.de](mailto:info@elobau.de)  
Web: [www.elobau.de](http://www.elobau.de)

 0123